

B

B

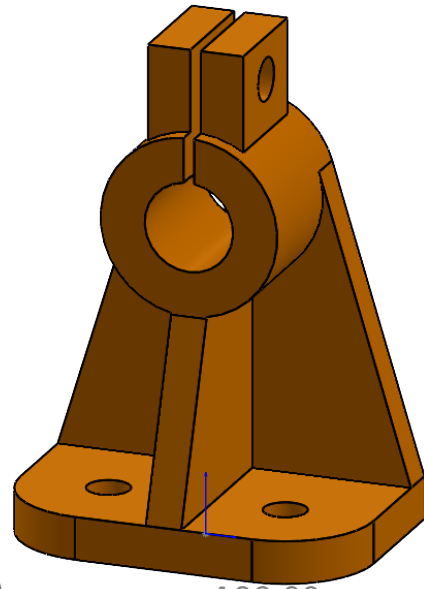

2 x  $\phi$  12.00 THRU

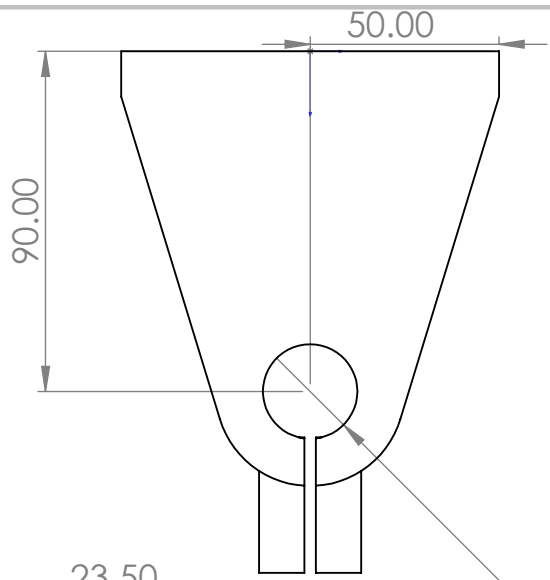
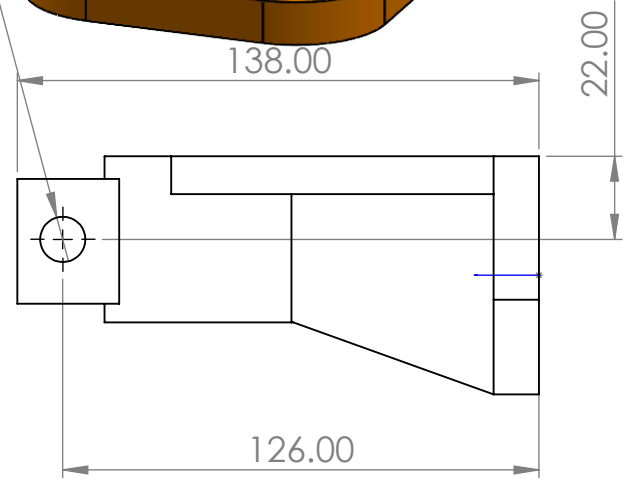
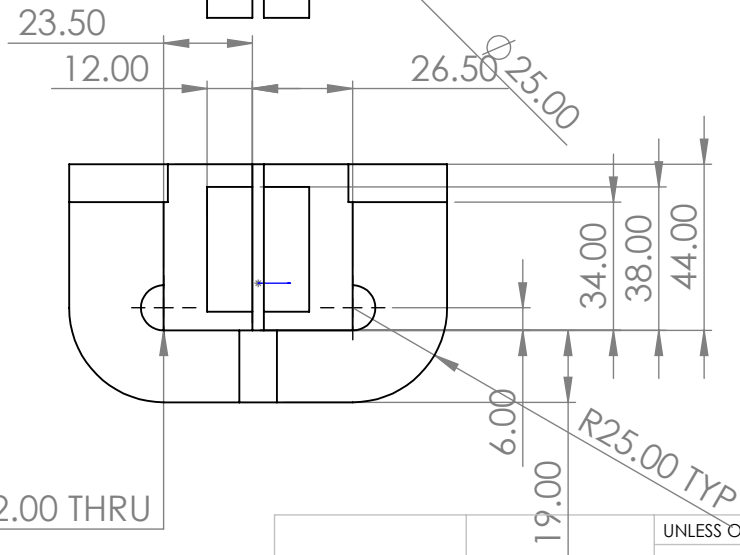

2 x  $\phi$  12.00 THRU

A

A

**PROPRIETARY AND CONFIDENTIAL**  
 THE INFORMATION CONTAINED IN THIS DRAWING IS THE SOLE PROPERTY OF <INSERT COMPANY NAME HERE>. ANY REPRODUCTION IN PART OR AS A WHOLE WITHOUT THE WRITTEN PERMISSION OF <INSERT COMPANY NAME HERE> IS PROHIBITED.

		UNLESS OTHERWISE SPECIFIED:		NAME	DATE
		DIMENSIONS ARE IN INCHES			
		TOLERANCES:			
		FRACTIONAL $\pm$			
		ANGULAR: MACH $\pm$ BEND $\pm$			
		TWO PLACE DECIMAL $\pm$			
		THREE PLACE DECIMAL $\pm$			
		INTERPRET GEOMETRIC TOLERANCING PER:			
		MATERIAL			
		FINISH			
NEXT ASSY	USED ON				
APPLICATION		DO NOT SCALE DRAWING			

<COMPANY NAME>		
TITLE:		
SIZE	DWG. NO.	REV
<b>A</b>	<b>WORK ONE</b>	
SCALE: 1:2	SHEET 1 OF 1	

2

1